



6200R



6200S

Linx Continuous Ink Jet Printers Models 6200S & 6200R

Linx continuous ink-jet (CIJ) printers are ideally suited for marking and coding a wide variety of products on the production line. Linx CIJ printers are fast, flexible and very easy to operate. They print on product and packaging surfaces of almost any size, shape or texture and have applications across a broad range of industries.

With its many advanced features and ability to print up to 4 lines, the Linx 6200 is ideal for applications requiring maximum flexibility.

Performance

Lines of print	1,2,3, or 4
Maximum speed: single line print at ideal pitch (midi printhead)	
standard speed model	2.57m/s
high speed/deluxe models	5.00m/s
Maximum number of characters per second (midi printhead)	
standard speed model	1212
high speed/deluxe models	1667
Character height range (printhead/model dependent)	0.8 to 25mm
Character patterns/rasters available (printhead/model dependent)	up to 15
Maximum message length (number of characters)	1365
Graphics/logos	•
Logo editor	•
Bar codes EAN, ITF, Code 39, Code 128, UPC-A	•

General Features

Single button start-up and shut-down	•
Menu-driven message creation and editing	•
Integral QWERTY keyboard (full size)	•
480 x 120 pixel LCD display	
(backlit, WYSIWIG, adjustable viewing angle)	•
Auto printhead flush	•
Auto power-off	•
Choice of operator languages	12
Operator languages per machine	12
Full diagnostic package	•
Printer status indicators (4 LEDs)	•



Top Elevation

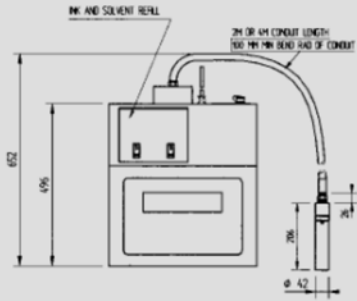

Front Elevation



Side Elevation

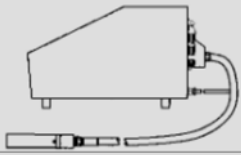

Model 6200S

Top Elevation

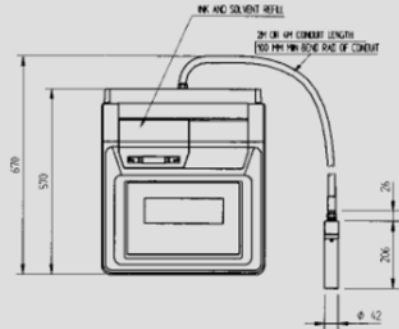

Front Elevation

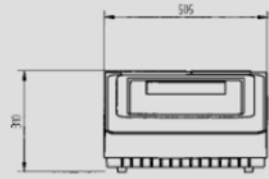

Side Elevation



Model 6200R

Programming and printing facilities

- Fixed and variable text
- Upper- and lower-case characters
- Bold factor up to 9 times
- Character height, width and delay functions
- Formats for shift coding, days, months
- Flexible date options
- Real-time clock functions
- Automatic date forward function
- Batch coding and counting
- Sequential numbering
- Sequential message fields
- Print go delay compensation
- Reverse printing
- Invert printing
- Rotated character printing
- Message creation/editing whilst printing
- Repeat-message function
- Timed-message function
- Production schedule
- LogoJet® PC-based message and logo creation software
- Snowflake™ Data Matrix two-dimensional dot coding

Optional*
Optional
Optional

Memory capacity

- Message storage capacity (number of messages) 999
- Logo storage capacity (number of logos) 300+

Printhead options

- Midi (62µm)
- Micro
- Macro
- Pigmented (70µm)
- 90° printhead configuration
- 2m conduit
- 4m conduit (midi, micro & pigmented printhead only)
- Positive air purge to printhead (midi & pigmented only)

Optional
Optional
Optional

Ink range

- Linx Marque MEK base (dye/pigmented)
- Linx Marque mixed base
- Linx Marque ethanol base
- Linx Marque food grade

Connections / interfacing for

- Shaft encoder
- Product detector
- Auxiliary product detector
- External alarm output
- Inputs/outputs for parallel connection
- RS232
- RS485
- DDE driver

10
Optional
Optional

Physical characteristics

- Nickel plated mild steel base with PU foam top cover
- Stainless steel enclosure
- Mounting options
- Operating temperature range
- Humidity range (r.h., non-condensing)
- Power supply
- Power rating
- Weight

6200R
6200S
floor, bench or console
5-40°C
10-90%
90-240V, 50/60Hz
200W
29kg

Regulatory approvals

- TÜV/GS
- CE mark
- FCC
- *Standard on DX models

